

4

3

2

RELEASED FOR PUBLICATION 28-JULY-82

© COPYRIGHT 1982 BY AMP INCORPORATED. ALL RIGHTS RESERVED.

| LOC |              | REVISIONS   |          |     |      |
|-----|--------------|-------------|----------|-----|------|
| P   | LTR          | DESCRIPTION | DATE     | DWN | APVD |
| D   | EB00-0487-99 |             | 8-11-99  | DRT | -    |
| E   | EB00-0150-00 |             | 15-03-00 | DRT |      |

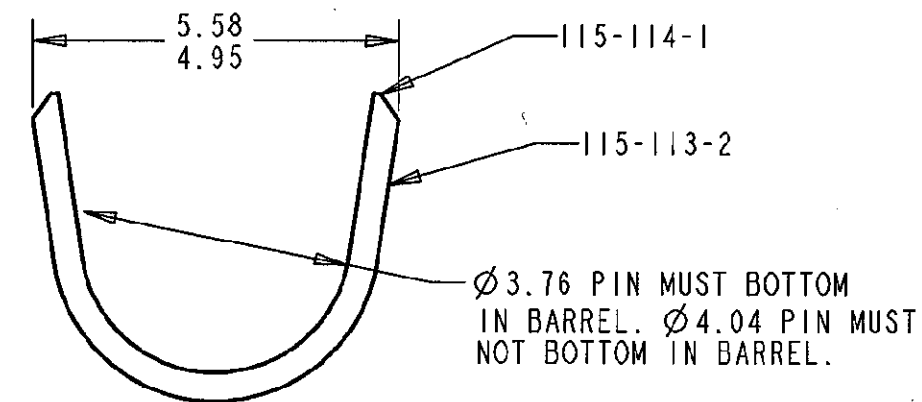
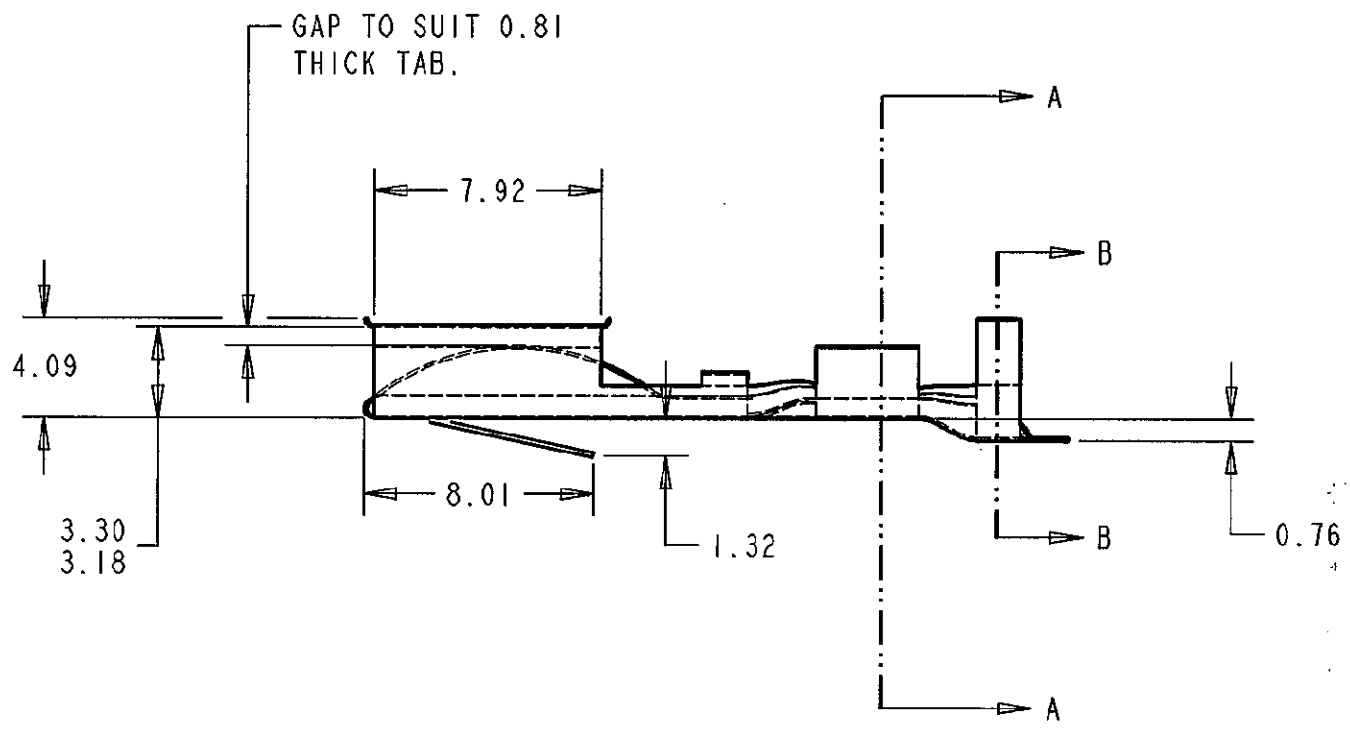
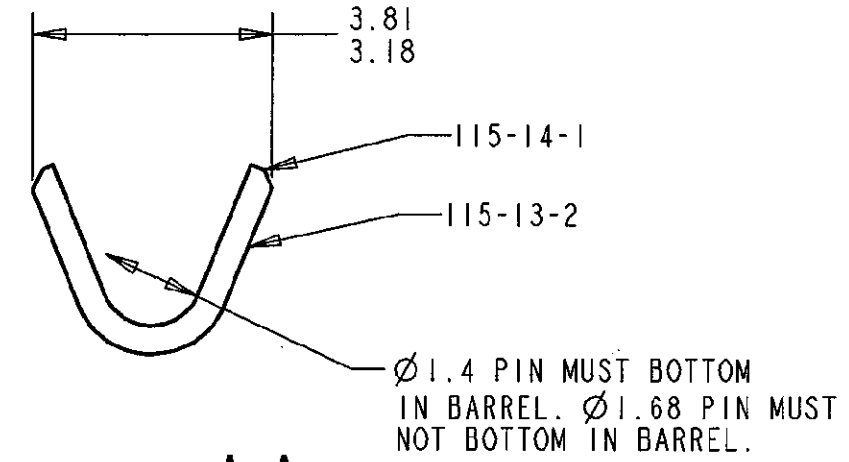
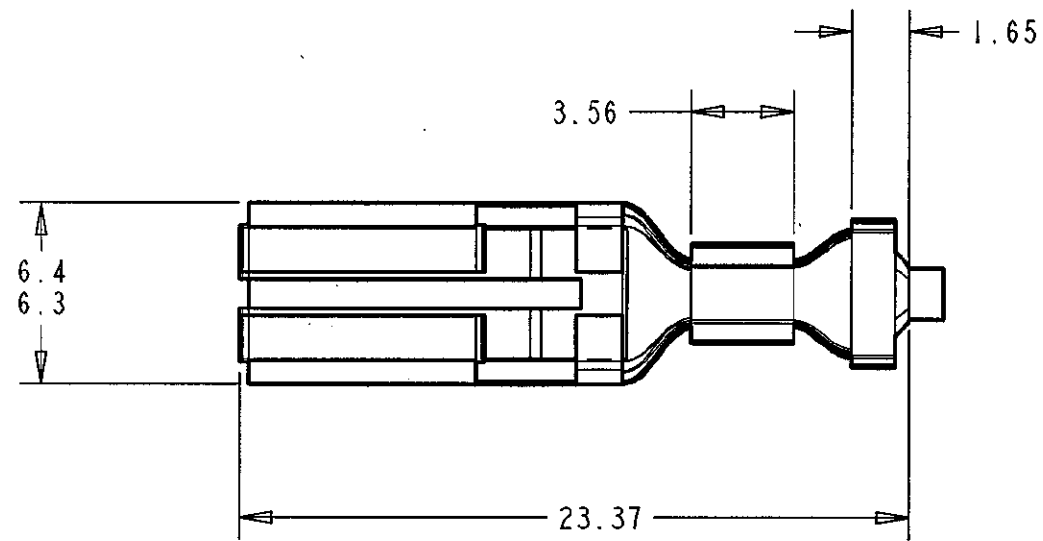

1. WIRE RANGE: -0.65-2.00 mm<sup>2</sup>.
2. INSULATION RANGE: -2.4-3.5.
3. REEL QUANTITY 2.5M.

|             |         |              |             |
|-------------|---------|--------------|-------------|
| 342873-4    | PRE-TIN | PHOS. BRONZE | 342413-4    |
| 342873-3    | NONE    | PHOS. BRONZE | 342413-3    |
| 342873-2    | PRE-TIN | BRASS        | 342413-2    |
| 342873-1    | NONE    | BRASS        | 342413-1    |
| LOOSE PIECE | FINISH  | MATERIAL     | PART NUMBER |

|                                                                                                                                                                               |                                        |                                 |                                                                                         |
|-------------------------------------------------------------------------------------------------------------------------------------------------------------------------------|----------------------------------------|---------------------------------|-----------------------------------------------------------------------------------------|
| THIS DRAWING IS A CONTROLLED DOCUMENT FOR AMP INCORPORATED. IT IS SUBJECT TO CHANGE AND THE CONTROLLING ENGINEERING ORGANIZATION SHOULD BE CONTACTED FOR THE LATEST REVISION. |                                        | DWN<br>D. R. TERRY<br>17-Mar-00 | <br>AMP of Great Britain Ltd,<br>Stanmore,<br>Middlesex, HA7 4RS.                       |
| DIMENSIONS IN m.m.                                                                                                                                                            |                                        | CHK<br>C. HALLETT<br>24-Mar-00  |                                                                                         |
| TOLERANCES UNLESS OTHERWISE SPECIFIED:<br>LINEAR: - ±0.5<br>ANGULAR: - ±1°                                                                                                    |                                        | APVD<br>C. K.<br>27-Mar-00      |                                                                                         |
| THIRD ANGLE PROJECTION                                                                                                                                                        | MATERIAL<br>0.4 THK STOCK<br>SEE TABLE | FINISH<br>SEE TABLE             | NAME<br><b>RECEPTACLE</b><br>SIZE<br>A3<br>CAGE CODE<br>00779<br>DRAWING NO<br>©-342413 |
| CUSTOMER DRAWING                                                                                                                                                              |                                        |                                 | SCALE 4:1 SHEET 1 OF 1 REV E                                                            |