

THIS DRAWING IS UNPUBLISHED. RELEASED FOR PUBLICATION  
 © COPYRIGHT - By - ALL RIGHTS RESERVED.

REVISIONS				
P	LTR	DESCRIPTION	DATE	APVD
C3		REVISED PER ECO-16-009052	24MAY2017	DD MT

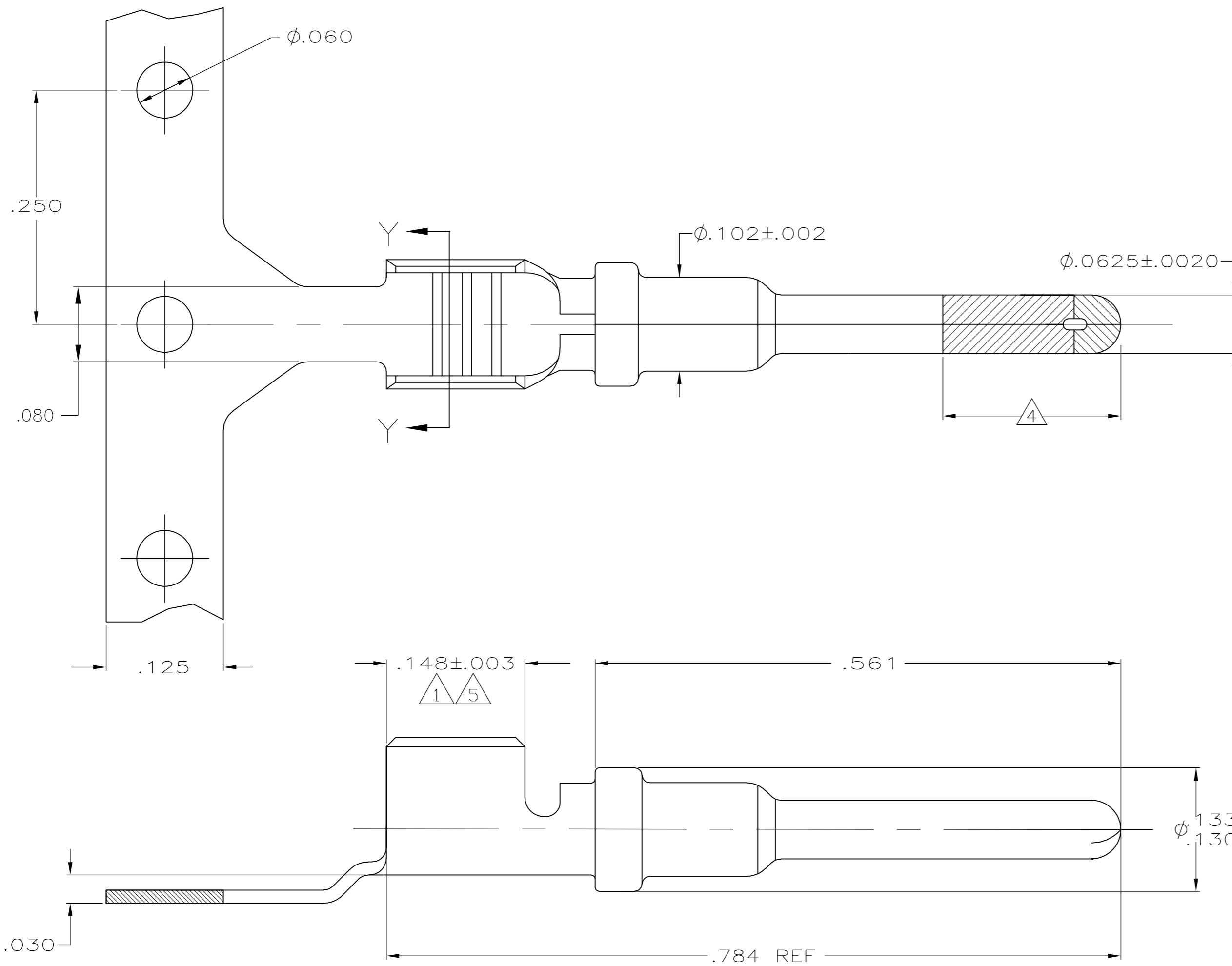

- 1. FINISH : PLATE 0.000100-0.000200 THK TIN IN LOCALIZED TIN PLATE AREA, ALL OVER 0.000030-0.000070 THK NICKEL.
- 2. CONTACT WILL BE LUBED WITH LUBRICANT PER P/N 22014-4.
- 3. WIRE RANGE: 18-14 AWG SXL, GXL, AND TXL WIRE WITH INSL DIAMETERS OF 0.077-0.155 INCHES.
- 4. PLATE 0.000030 MIN THK SELECT GOLD IN LOCALIZED PLATE AREA.
- 5. PLATE .000100-.000200 THK TIN PER 112-65-1 IN LOCALIZED TIN PLATE AREA. ALL OVER .000040-.000080 THK NICKEL PER 112-25-2

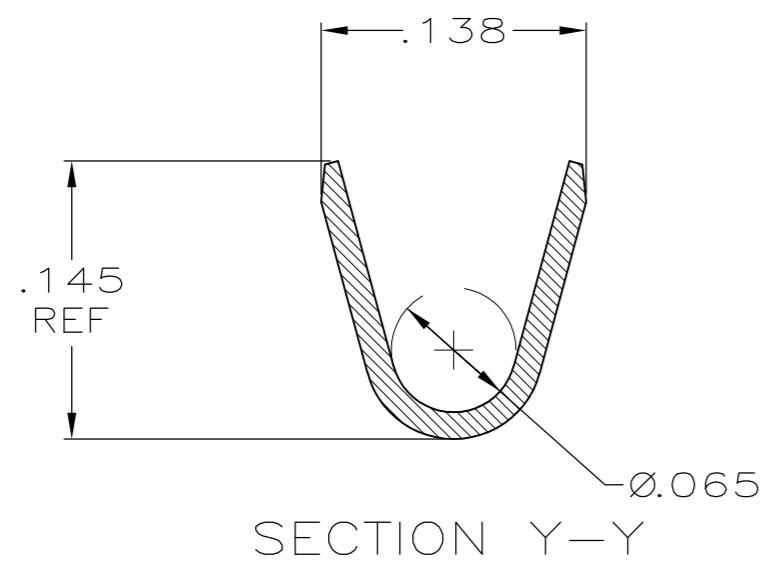

THIS DRAWING IS A CONTROLLED DOCUMENT.		DWN	JL MCNEAL	9-30-97	638112-3	
DIMENSIONS: INCHES		CHK	-	-	638112-1	
TOLERANCES UNLESS OTHERWISE SPECIFIED:		APVD	W. LONG	10-1-97	TE Connectivity	
0 PLC ± -		PRODUCT SPEC	PIN CONTACT, WIRE-TO-WIRE			
1 PLC ± -		APPLICATION SPEC	SIZE CAGE CODE DRAWING NO RESTRICTED TO			
2 PLC ± .02		WEIGHT		0.000000	A2 00779	C=638112
3 PLC ± .005		CUSTOMER DRAWING		SCALE	10:1	SHEET 1 of 1
4 PLC ± -		MATERIAL		REV C3		
ANGLES ± -		BODY: 0.014 THK COPPER ALLOY				
FINISH -						