

SYMBOL DEFINITION		MISSING SYMBOLS	
A DIMENSION WITHOUT AN INSPECTION REPORT SYMBOL DOES NOT REQUIRE INSPECTION. IT MAY BE CONTROLLED ON THE INDIVIDUAL COMPONENT DRAWING.	TOTAL NO OF INSPECTIONS REQUIRED	NO MISSING SYMBOL NUMBER	
	19		
	LAST NO. USED		
	12		

DWG STATUS				REVISION HISTORY				AUTH	DR	APVD	APVD	
DATE	STG	REV	W/P	CHG	ZONE	Cleared revision col. Mat'l spec was R0071784, added DELPHI logo and notes 2 & 5 and revised graphics						
14.JUN02	R	C5	-	-		22644B			ARA	BEG	GM	
14.JUN02	R	C6	-	-		UPDATED PDM ATTRIBUTES			229413	ARA	BEG	GM

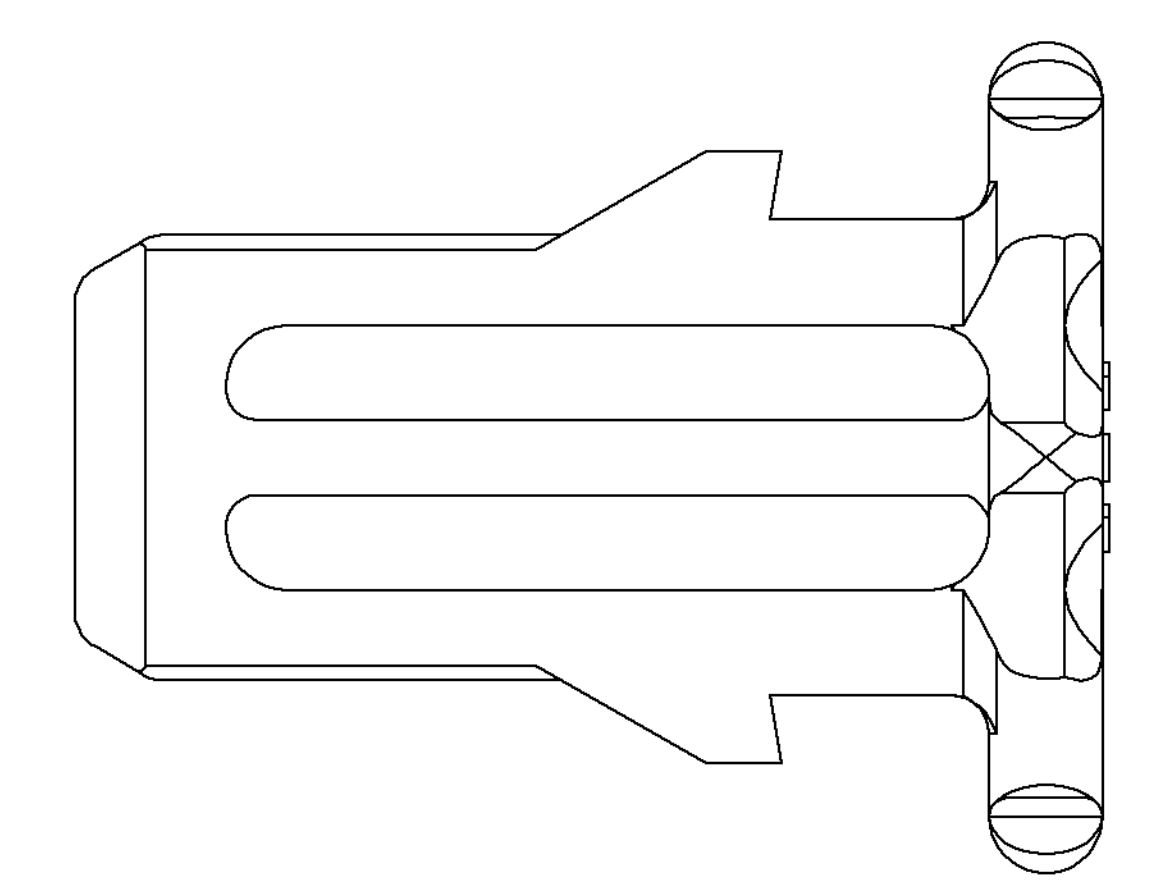

OPTIONAL CONSTRUCTION
EJECTION FLAT

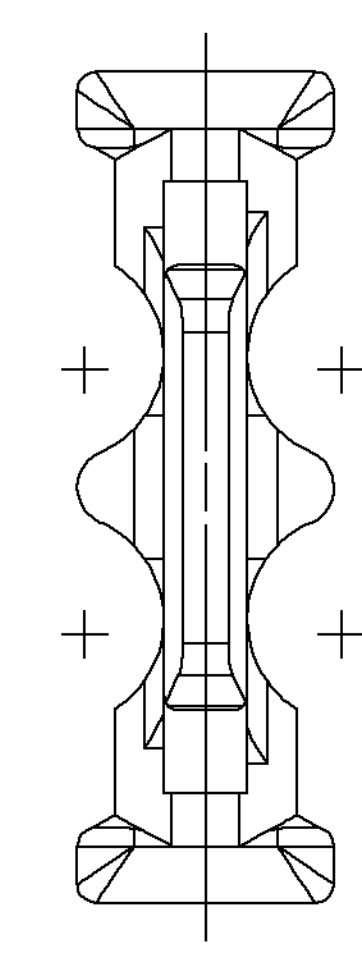
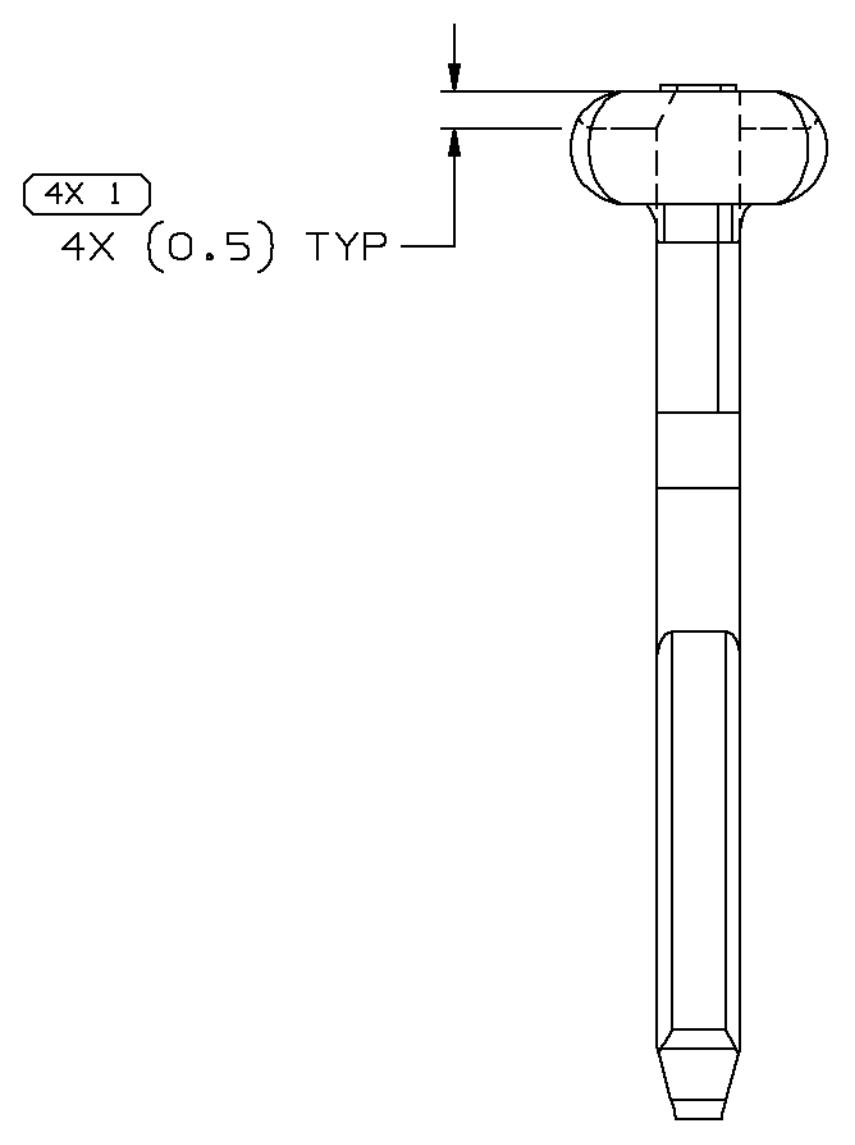
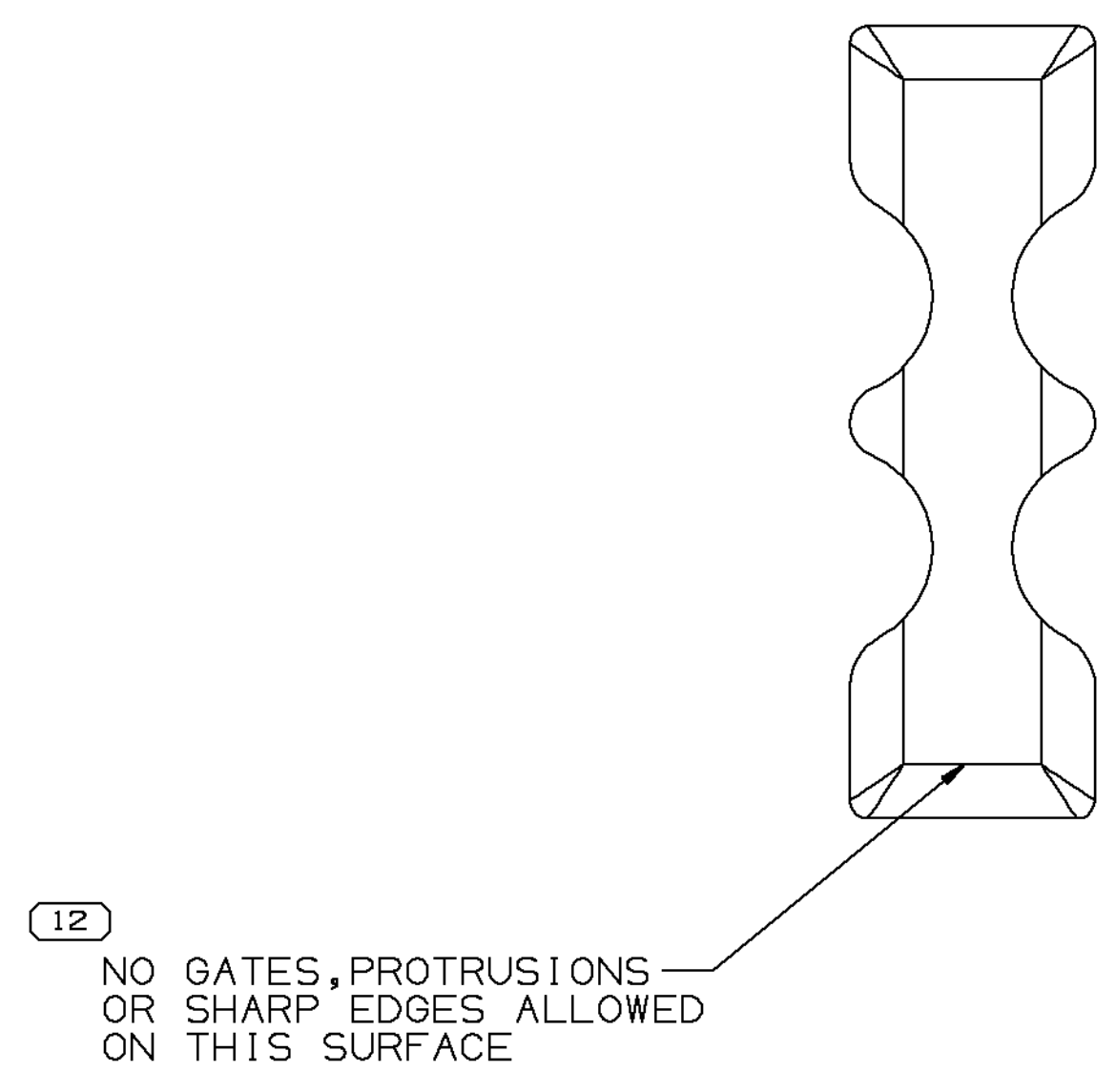
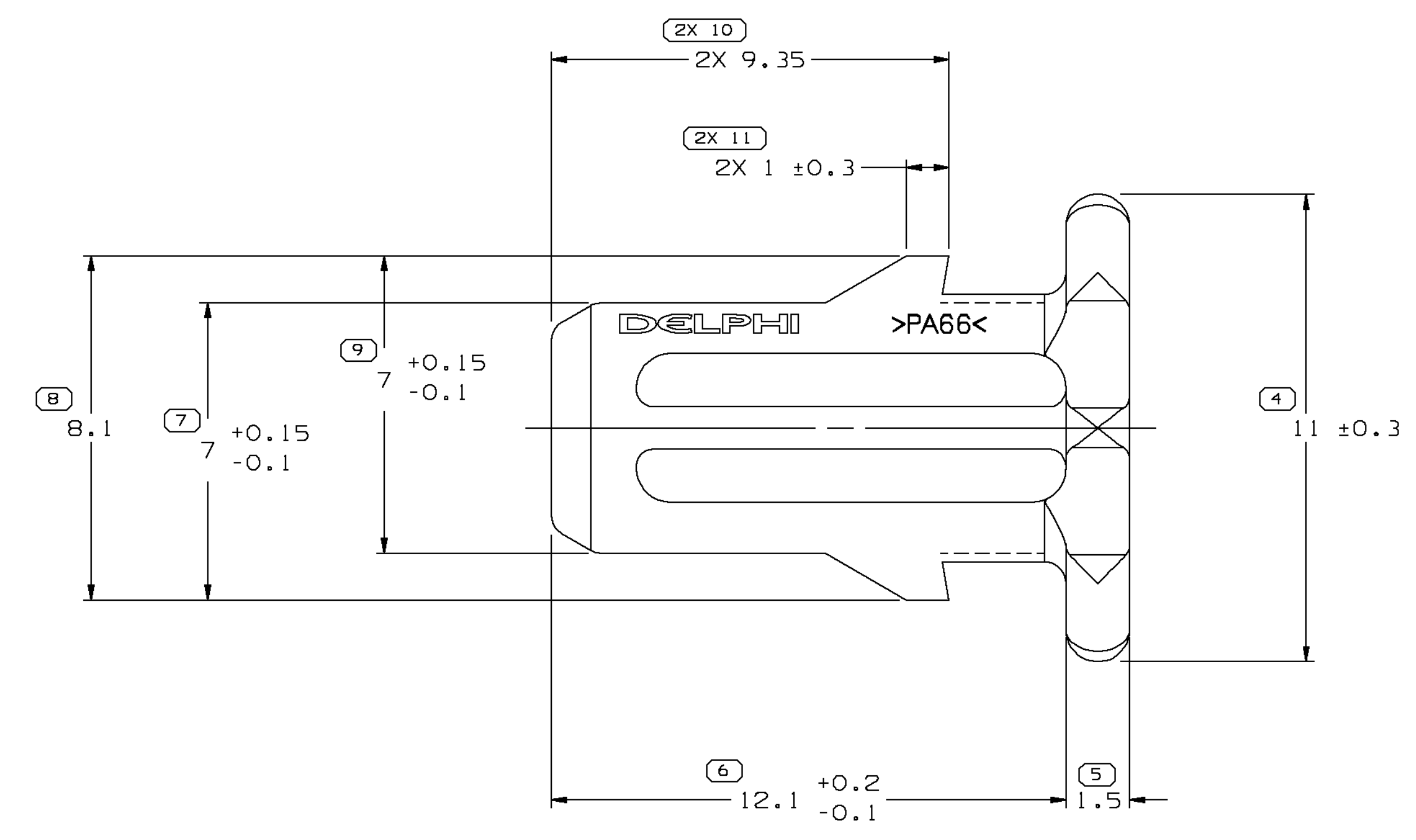
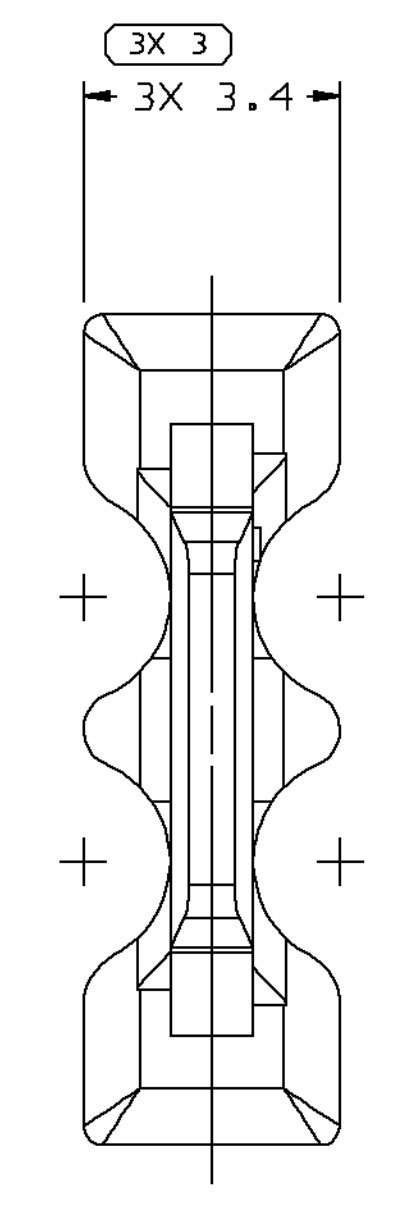
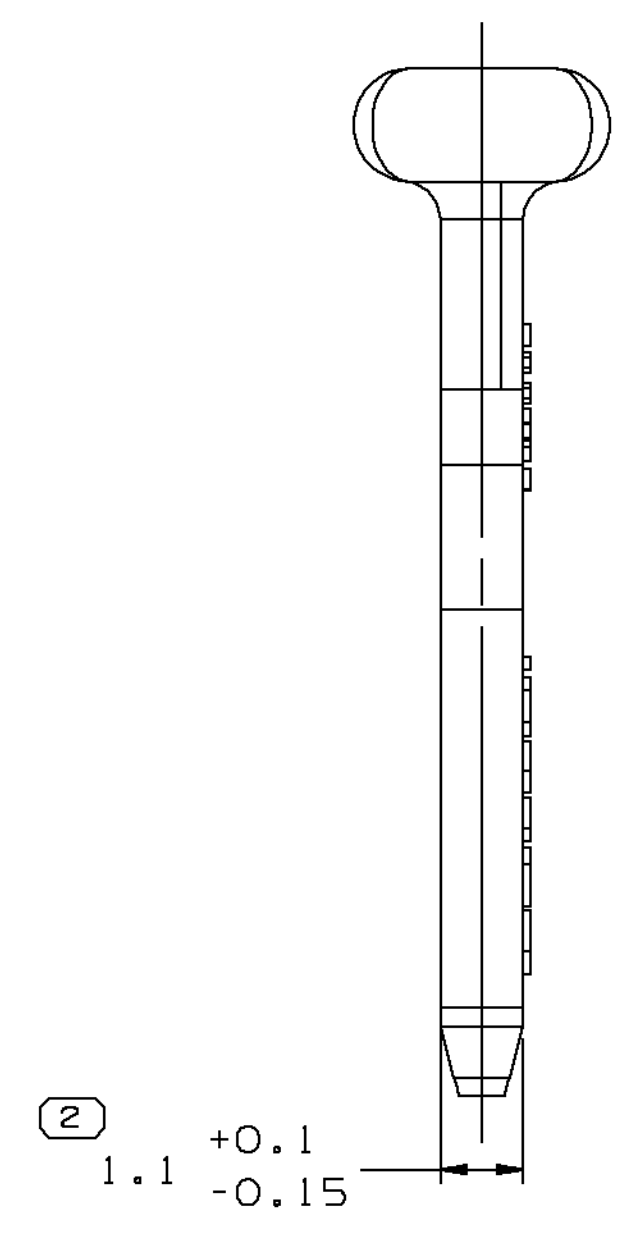
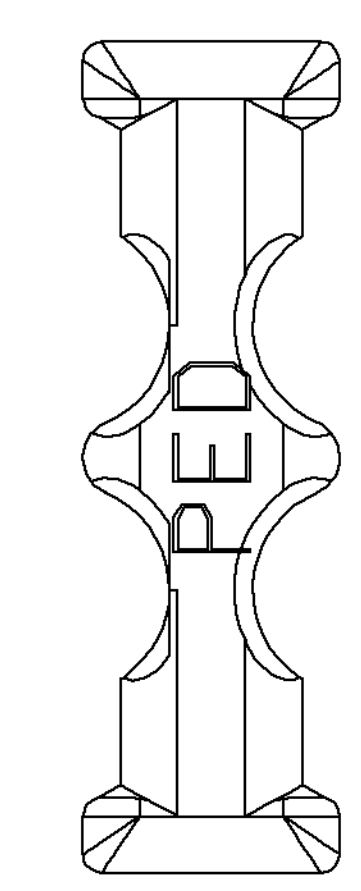

NOTES

- UNLESS OTHERWISE SPECIFIED AND/OR INDICATED: DIMENSIONS ARE TO FACE OF VIEW SHOWN AND AUTOMATICALLY ROUNDED BY COMPUTER FOR INSPECTION (SEE MATH MODEL FOR PRECISE DIMENSIONS). FOR ALL OTHER DIMENSIONS NOT SHOWN BUT REQUIRED FOR TOOL BUILD, SEE MATH MODEL FOR PRECISE TOOL PATH DATA.
- MATERIAL RECYCLING CODE >PA66< PER SAE J1344. (0.1)X(0.1) RAISED CHARACTERS AS SHOWN TO BE LOCATED ON ANY EXTERIOR SURFACE. OPTIONAL CONSTRUCTION TO BE NO MATERIAL RECYCLING CODE.
- THIS PART IS NOT CONTROLLED FOR AUTOMATIC FEEDING.
- MATING COMPONENTS OR EQUIVALENT: CONNECTOR 12047663
- (0.4)X(0.1) RAISED DELPHI CORPORATE BRAND TO BE LOCATED ON ANY EXTERIOR SURFACE, PREFERABLY VISIBLE AT FINAL ASSEMBLY. OPTIONAL CONSTRUCTION TO BE "PED" OR NO LOGO.
- PART IS SYMETRICAL ABOUT ITS CENTERLINE.

VIEW SCALE DOES NOT
REFLECT THE ACTUAL PART SIZE

	PROCESS SENSITIVE DIMENSION		THIRD ANGLE PROJECTION		DO NOT SCALE
	DIMENSIONS ENCLOSED IN () INDICATE REFERENCE DIMENSIONS AND NO TOLERANCE LIMITS ARE ESTABLISHED				USE MATH DATA

FROM	TO	TOLERANCE UNLESS OTHERWISE SPECIFIED
0	20	±0.15
20	30	±0.2
30	50	±0.3
50	70	±0.4
70	100	±0.5
100	150	±0.6
150	200	±0.8
200	250	±1
250	300	±1.2
300	400	±1.5

CHART	ET
1	1

DELPHI
DELPHI PACKARD ELECTRIC SYSTEMS
WARREN, OH

DR	DATE
APVD1 H. HERNANDEZ	23NOV00
APVD2 E. VAZQUEZ	25NOV00
APVD3 G. MACIAS	27NOV00
APVD4	
APVD5	

MATERIAL: M3592025 PA66 HS 1M GRA MD

DRAWING NAME: TPA M/P 150

DRAWING NUMBER: 12047665

SIZE: A0 SCALE: 10:1 FRAME NO: 1 OF 1 SHEET NO: 1 OF 1 STG: R REV: C5