

SYMBOL DEFINITION		MISSING SYMBOLS	
A DIMENSION WITHOUT AN INSPECTION REPORT SYMBOL DOES NOT REQUIRE INSPECTION. IT MAY BE CONTROLLED ON THE INDIVIDUAL COMPONENT DRAWING.	TOTAL NO OF INSPECTIONS REQUIRED	NO MISSING SYMBOL NUMBER	
	13		
	LAST NO. USED		
	11		

DWG STATUS					REVISION HISTORY		AUTH	
DATE	STG	REV	N/P	CHG	ZONE			
31MY06	R	01	-	-		ALL PARTS - REDRAWN TO PD		279436 JAR JAA WTM
13AU12	R	02	-	-		ALL PARTS - UPDATED MATERIAL CALLOUT		419206 CBG/CB6/MAA M

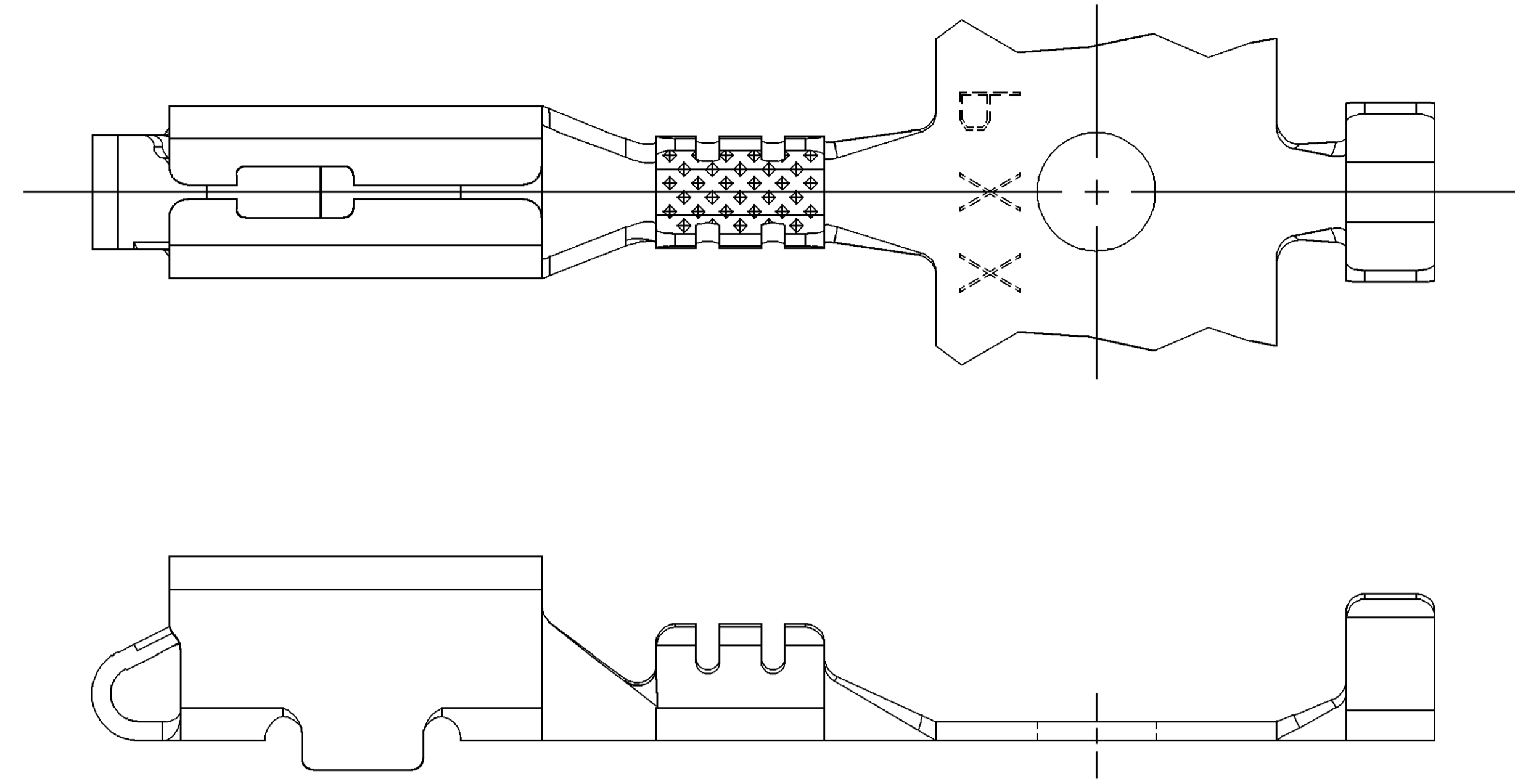

TYPE 102
SAME AS TYPE 101
EXCEPT AS SHOWN

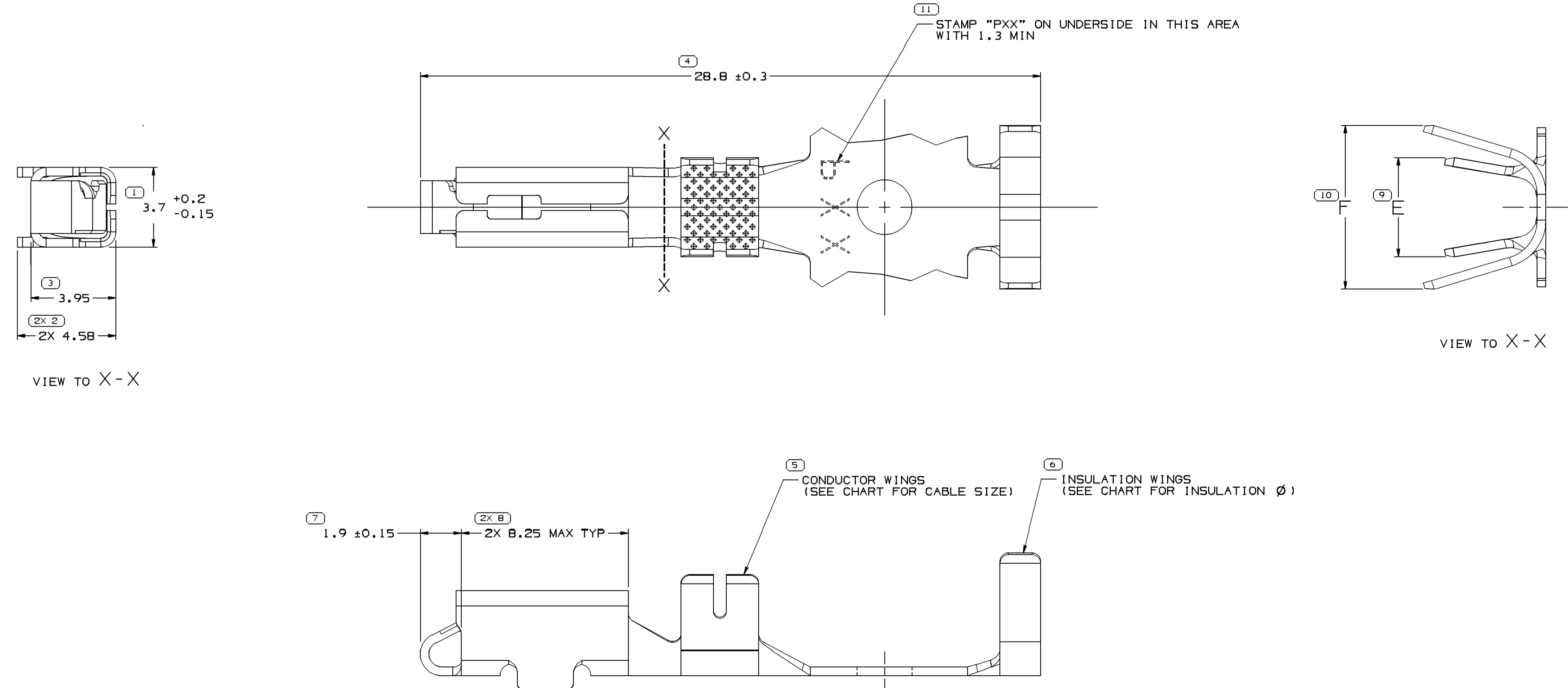
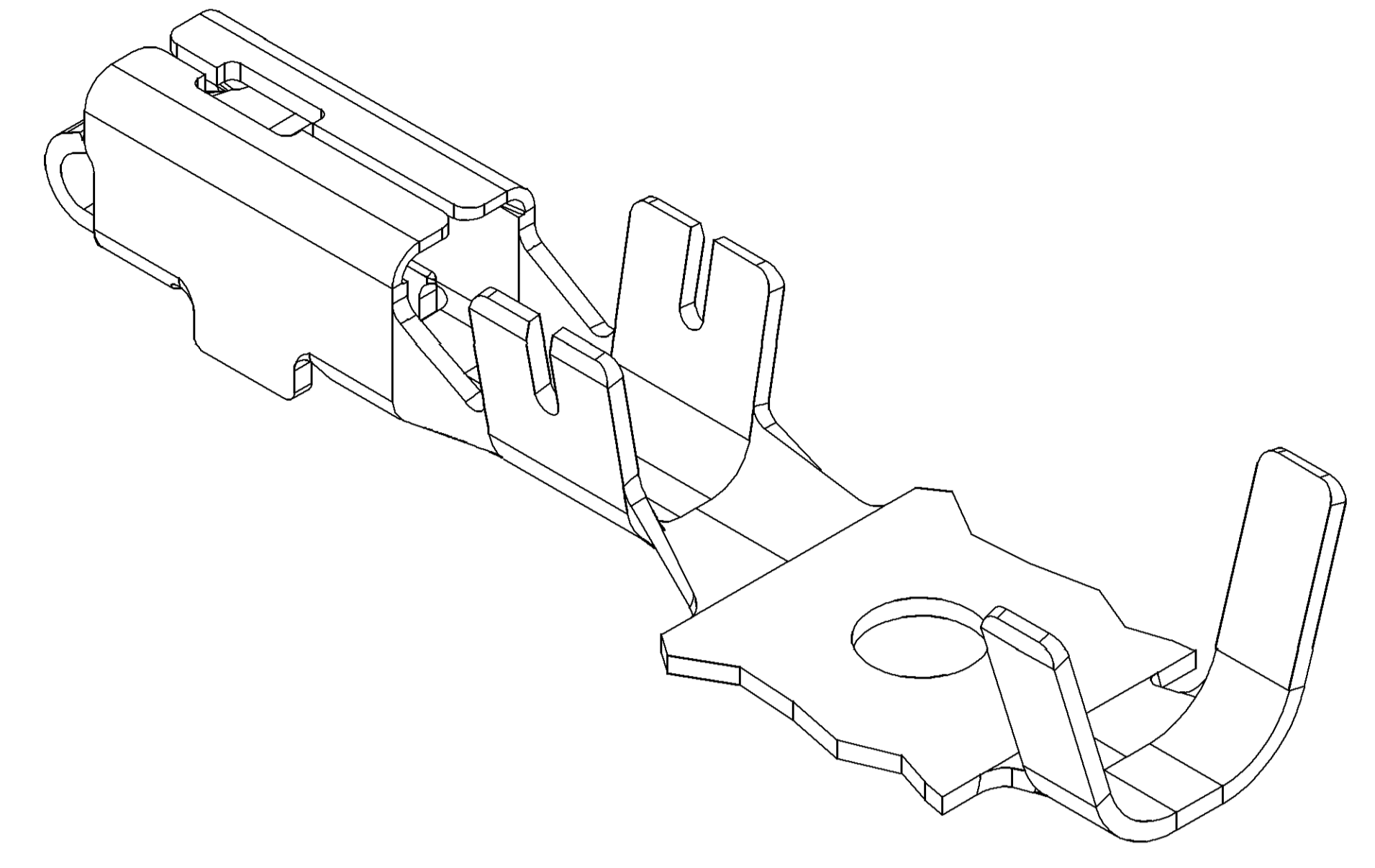

TYPE 101

- NOTES
- UNLESS OTHERWISE SPECIFIED AND/OR INDICATED:
DIMENSIONS ARE TO FACE OF VIEW SHOWN AND AUTOMATICALLY ROUNDED BY COMPUTER FOR INSPECTION (SEE MATH MODEL FOR PRECISE DIMENSIONS). FOR ALL OTHER DIMENSIONS NOT SHOWN BUT REQUIRED FOR TOOL BUILD, SEE MATH MODEL FOR PRECISE TOOL PATH DATA.
 - REFERENCE MATING COMPONENTS OR EQUIVALENT:
TERMINAL MINI FUSE 12092075
RECOMMENDED MATING BLADE 0.860/0.790 THK;
2.9/2.7 WIDTH; 7 LENGTH
 - MAXIMUM CURRENT CAPACITY IS 30 AMPS.
 - DO NOT PROBE, TEST OR OTHERWISE CONTACT THE INTERIOR REGION (THE SPRING OR ANY MOVING PART) OF THIS TERMINAL. SEVERE DAMAGE CAN OCCUR, COMPROMISING THE PERFORMANCE OF THE ELECTRICAL INTERFACE.

PART NO	REV	N/P	STATUS	MAT'L SIZE	MAT'L SPEC	PART NO	REV	N/P	STATUS	MAT'L SIZE	MAT'L SPEC	CABLE	DIA	ID	TYPE
12110685	A2	-	-	0.406 X 34.39	TIN PLATED COOPER ALLOY	TWO 0.5	2.2-1.7	220	102	3.5	5.8				
12110664	A2	-	-	0.406 X 34.39	TIN PLATED COOPER ALLOY	TWO 0.35	TWO 2.1 MAX	222	102	2.7	5.3				
12110662	A2	-	-	0.406 X 34.39	TIN PLATED COOPER ALLOY	TWO 1-0.8	2.7-1.9	217	101	4.2	6.7				
12110647	C2	-	-	0.406 X 34.39	TIN PLATED COOPER ALLOY	5	4.48-3.72	10	101	4.6	7.6				
12110646	C2	-	-	0.406 X 34.39	TIN PLATED COOPER ALLOY	3-2	3.65-2.5	13	101	4	5.6				
12110645	C2	-	-	0.406 X 34.39	TIN PLATED COOPER ALLOY	1-0.8	2.64-1.96	17	102	2.9±0.2	4.6				
12110644	C2	-	-	0.406 X 34.39	TIN PLATED COOPER ALLOY	0.5-0.35	2.19-1.47	21	102	2.4±0.2	3.8±0.2				

UNLESS OTHERWISE SPECIFIED

THIS DOCUMENT IS IN ACCORDANCE WITH ASME Y14.5M-1994 AS MODIFIED BY THE 2003 SUPPLEMENT AND TELEPHONIC ADDENDUM-2001. SEPARATE PATTERNS OF FEATURES MAY BE SHOWN SEPARATELY, RESPECTIVE OF DATUM REFERENCES.

ALL DIMENSIONS ARE IN MILLIMETERS

REFERENCE

THIRD ANGLE PROJECTION

DO NOT SCALE

USE MATH DATA

ANGULAR TOLERANCE 12°

DELPHI
DELPHI PACKARD ELECTRICAL/ELECTRONIC ARCHITECTURE
WARREN, OH
COPYRIGHT 2006 DELPHI CORPORATION AND/OR ITS AFFILIATES. ALL RIGHTS RESERVED.
THIS DRAWING IS THE PROPERTY OF DELPHI CORPORATION. THE REPRODUCTION, DISTRIBUTION AND UTILIZATION OF THIS DOCUMENT OR ITS RELATED CAD DATA, AS WELL AS COMMUNICATION OF ANY CONTENT TO OTHERS, WITHOUT EXPRESS AUTHORIZATION IS PROHIBITED.

DRAWING NUMBER: TAXI TERM F M/P 280 SN

DRAWING NUMBER: 12110643

SIZE: A0
SCALE: 10:1
FRAME NO: 1 OF 1
SHEET NO: 1 OF 2
STG: R
REV: 02