

1

2

3

△	PART NO. AND CH. CODE	MATERIAL	COLOR	APPLICABLE PART NO.
	7157-6520-80	PA66	BROWN	7122-1824-40 ETC. 7223-1824-40 ETC.

B

A

B

A

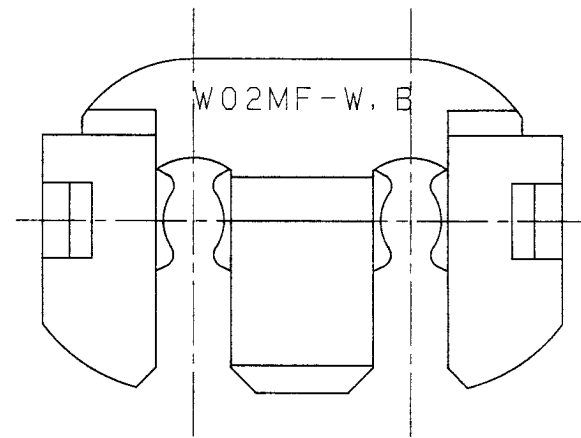
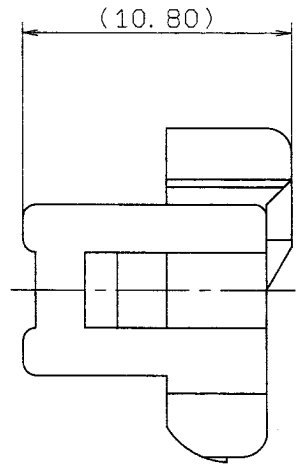
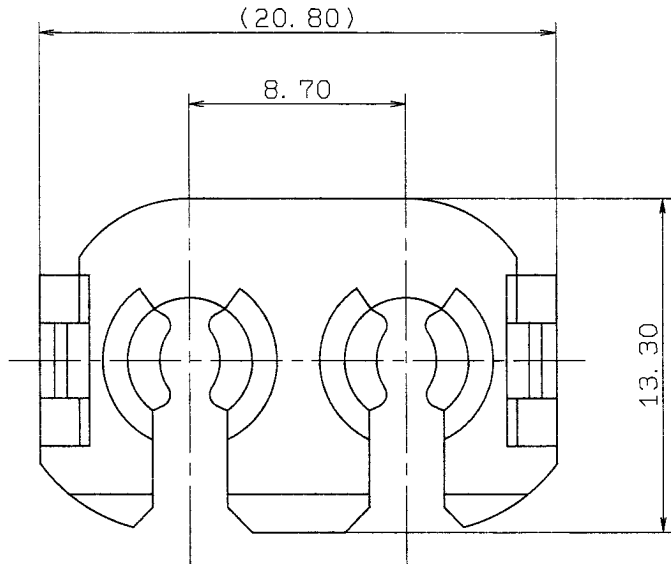

ISSUE MARK

△	99.09.16	ADDED APPLICABLE PART NO.	C99-M404	H. K	CUSTOMER	CUSTOMER PART NO.	CUSTOMER DWG NO.	MATL. SPEC.	SEE TABLE	TREAT. & FIN.					
	88.12.12	NEW	8MC-3185	T.M	OFFICE	TRIAL PART NO.		NAME	REAR HOLDER FOR						
LET	DATE	REVISION RECORD	NO.	CHKD	VENDOR			W TYPE CONNECTOR 2PM. FW, B							
GENERAL TOLERANCE					VENDOR NO.			PART NO.	7157-6520-80						
	10MAX	50MAX	100MAX	250MAX	250OVR	ANGLE	ECCENT	DWG TYPE	DWG SOURCE	DWG DATE	UNIT	SCL	ANGLE	CH. CODE	
A	±0.15	±0.2	±0.3	±0.5	±0.75	±30'	0.1	R	NEW	88.10.24	mm	5/1	3	DWG NO.	7157-6520-80:R
B	±0.2	±0.3	±0.55	±0.95	±1.4	±30'	0.1	APPROVED	CHECKED	CHECKED	DESIGN	DRAWN	SET DWG NO.		
©	±0.3	±0.5	±0.8	±1.4	±2	±30'	0.15				SATOH	MIYAZAKI			
SPECIFIED					MASS									YAZAKI CORPORATION	

1

2

3

