

Knock Sensor KS4-P



- ▶ Frequency: 3 to 25 kHz
- ▶ Weight: 48 g
- ▶ Height sensor head: 18 mm

This sensor is used for detecting structural born vibrations in spark ignition engines due to uncontrolled combustion. This sensor is suitable for operation in extreme conditions.

Due to the inertia of the seismic mass, the sensor moves in correlation to the engine block vibration; this motion results in a compressive force which is converted into a voltage signal via a piezoceramic sensor element. As a result, upper and lower voltage thresholds can be defined directly correlating to an acceleration magnitude.

The main benefits of this sensor are its robust mechanical design, compact housing and precise determination of structure-related noise. The small packaging is accomplished by integrating the connector directly to the sensor.

Application

Application	3 to 25 kHz
Operating temperature range	-40 to 150°C
Storage temperature range	-30 to 60°C
Max. vibration	≤ 800 m/s ²

Technical Specifications

Mechanical Data

Male thread (for cast)	M8x25
Male thread (for Al)	M8x30
Installation torque	20±5 Nm
Weight w/o wire	48 g
Protection	IP X9K

Electrical Data

Range of frequency	3 to 25 kHz
Sensitivity at 5 kHz	26 ± 8 mV/g
Max. sensitivity changing (lifetime)	-17 %
Linearity between 5 to 15 kHz (from 5 kHz value)	-10 to 10 %
Linearity between 15 to 20 kHz (linear increasing with freq)	20 to 50 %
Main resonance frequency	30 kHz
Impedance	> 1 MOhm
Temperature dependence of sensitivity	0.04 mV/g°C
Capacity field	1,150 ± 200 pF

Connectors and Wires

Mating connector 2-pole	2-Pin RB-Kp.1 (F02U.B00.966-01) or 2-Pin Jetronic (D261.205.288-01)
Pin 1	Sig+
Pin 2	Sig-

Installation Notes

The KS4-P can be connected to all Bosch Motorsport ECUs featuring knock control

The sensor must rest directly on the brass compression sleeve during operation.

To ensure low-resonance coupling of the sensor to the measurement location, the contact surface must be clean and properly machined to provide a secure flush mounting.

Please route the sensor wire in a way that prevents resonance vibration.

Please find further application hints in the offer drawing at our homepage.

Safety Note

The sensor is not intended to be used for safety related applications without appropriate measures for signal validation in the application system.

Legal Restrictions

Due to embargo restrictions, sale of this product in Russia, Belarus, Iran, Syria, and North Korea is prohibited.

Ordering Information

Knock Sensor KS4-P

Mating Connector: 2-Pin RB-Kp.1

Order number **0261.231.173**

Knock Sensor KS4-P

Mating Connector: 2-Pin Jetronic

Order number **0261.231.188**

Dimensions

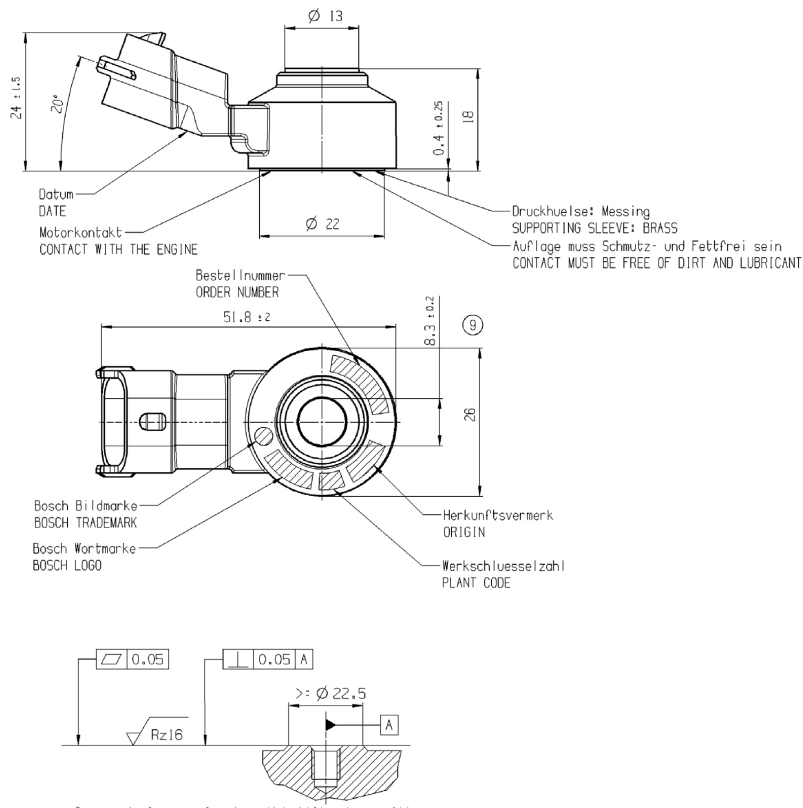

Represented by:

Europe:
 Bosch Engineering GmbH
 Motorsport
 Robert-Bosch-Allee 1
 74232 Abstatt
 Germany
 Tel.: +49 7062 911 9101
 Fax: +49 7062 911 79104
 motorsport@bosch.com
 www.bosch-motorsport.de

North America:
 Bosch Engineering North America
 Motorsport
 38000 Hills Tech Drive
 Farmington Hills, MI 48331-3417
 United States of America
 Tel.: +1 248 876 2977
 Fax: +1 248 876 7373
 motorsport@bosch.com
 www.bosch-motorsport.com

Asia-Pacific:
 Bosch Engineering Japan K.K.
 Motorsport
 18F Queen's Tower C, 2-3-5 Minato
 Mirai Nishi-ku, Yokohama-shi
 Kanagawa 220-6218
 Japan
 Tel.: +81 45 650 5610
 Fax: +81 45 650 5611
 www.bosch-motorsport.jp

Australia, New Zealand and South Africa:
 Robert Bosch Pty. Ltd
 Motorsport
 1555 Centre Road
 Clayton, Victoria, 3168
 Australia
 Tel.: +61 (3) 9541 3901
 motor.sport@au.bosch.com