

THIS DRAWING IS UNPUBLISHED.

RELEASED FOR PUBLICATION

ALL RIGHTS RESERVED.

© COPYRIGHT - By -

REVISIONS

P	LTR	DESCRIPTION	DATE	DWN	APVD
	J2	REVISED PER ECR-20-101061	14JAN2021	BH	E.W

FITS .250 SERIES FASTON RECEPTACLE

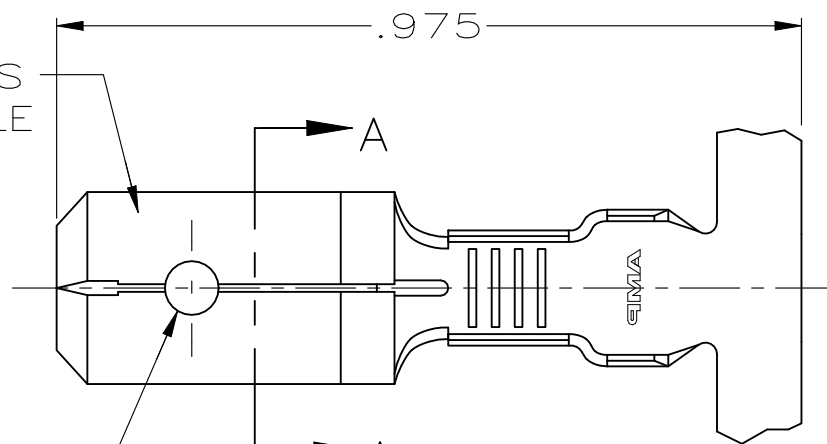

.075
.060 DIA HOLE

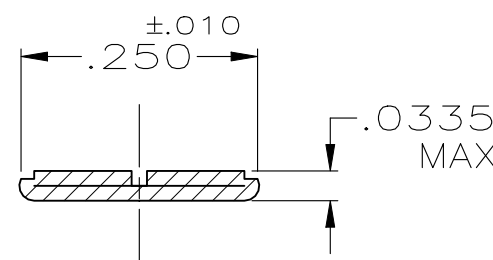

SECTION A-A
SCALE 5:1

- 1 CONTINUOUS STRIP ON REELS.
- 2 FEED TO BE .540±.005.
- 3 REVERSED REEL OF 42475-1.
- 4 REVERSED REEL OF 42475-2.
- 5 FOREIGN PRODUCTION ONLY.

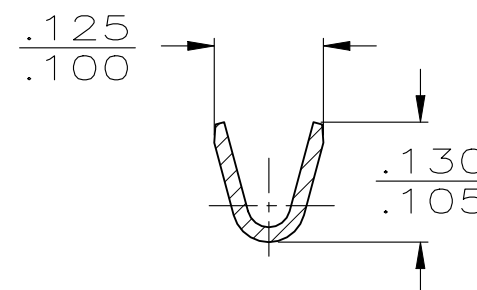
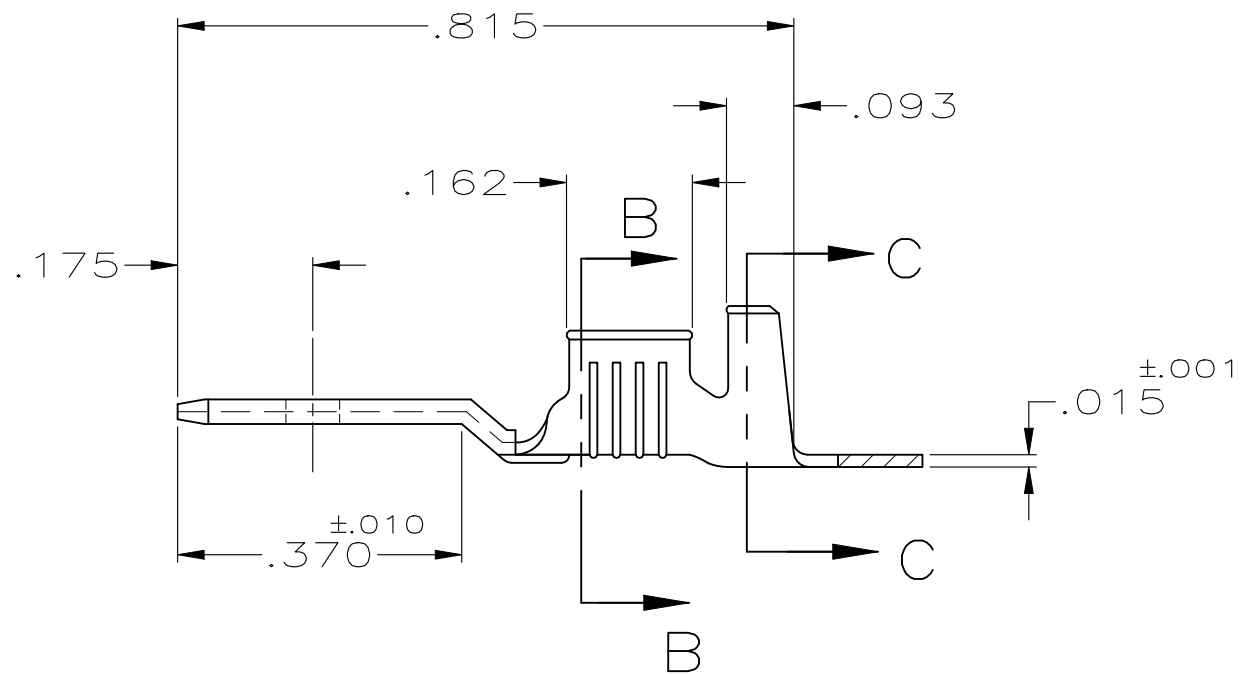

SECTION B-B
SCALE 5:1

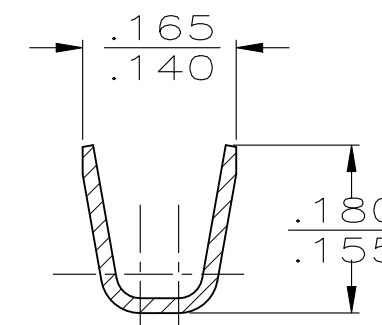

SECTION C-C
SCALE 5:1

FINISH	INSULATION RANGE	WIRE SIZE	PART NO
4 PRE-TIN	.080-.120 DIA	22-18 AWG	42475-5
4 TIN			42475-4
3 -			42475-3
5 TIN			42475-2
5 -			42475-1

THIS DRAWING IS A CONTROLLED DOCUMENT.		DWN JR RUTH 1/31/91	TE Connectivity		
DIMENSIONS: INCHES		CHK MS FEHER 1/31/91			
TOLERANCES UNLESS OTHERWISE SPECIFIED:		APVD C MEYERS 1/31/91	NAME TAB, FASTON, .250 SERIES		
		PRODUCT SPEC -	SIZE	CAGE CODE	DRAWING NO
0 PLC ± - 1 PLC ± - 2 PLC ± - 3 PLC ± .015 4 PLC ± - ANGLES ± -		APPLICATION SPEC -	A3	00779	C-42475
MATERIAL BRASS		FINISH SEE TABLE	WEIGHT 0.000000	RESTRICTED TO -	
CUSTOMER DRAWING			SCALE 4:1	SHEET 1 OF 1	REV J2